

Feb. 17, 1970

M. W. MAIER

3,495,582

REMOVABLE DOOR CONSTRUCTION FOR OVENS

Filed May 17, 1968

2 Sheets-Sheet 1

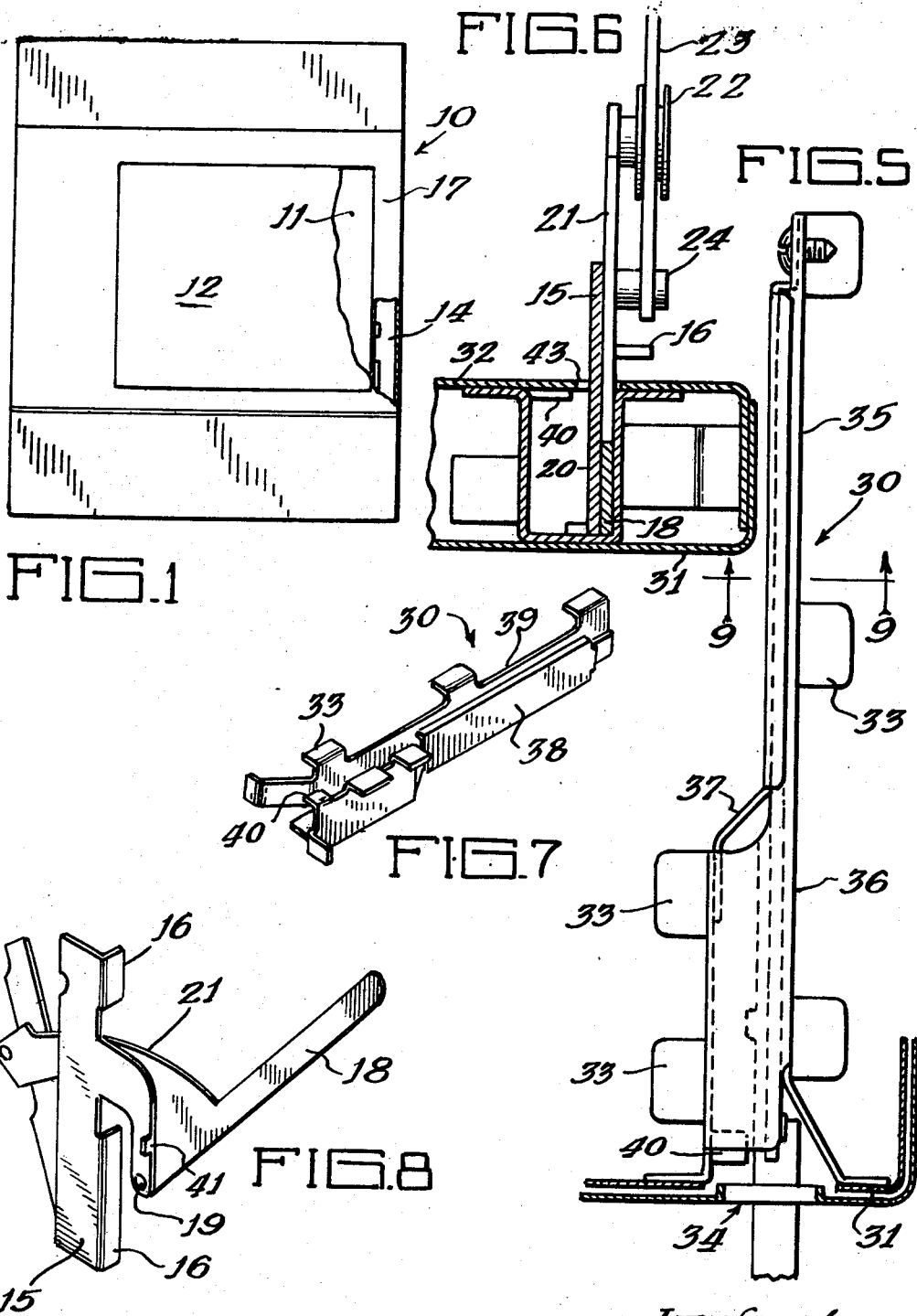

Inventor:
Michael W. Maier
By: Zahl, Baker, York,
Jones & Dittman
Attorneys

Feb. 17, 1970

M. W. MAIER

3,495,582

REMOVABLE DOOR CONSTRUCTION FOR OVENS

Filed May 17, 1968

2 Sheets-Sheet 2

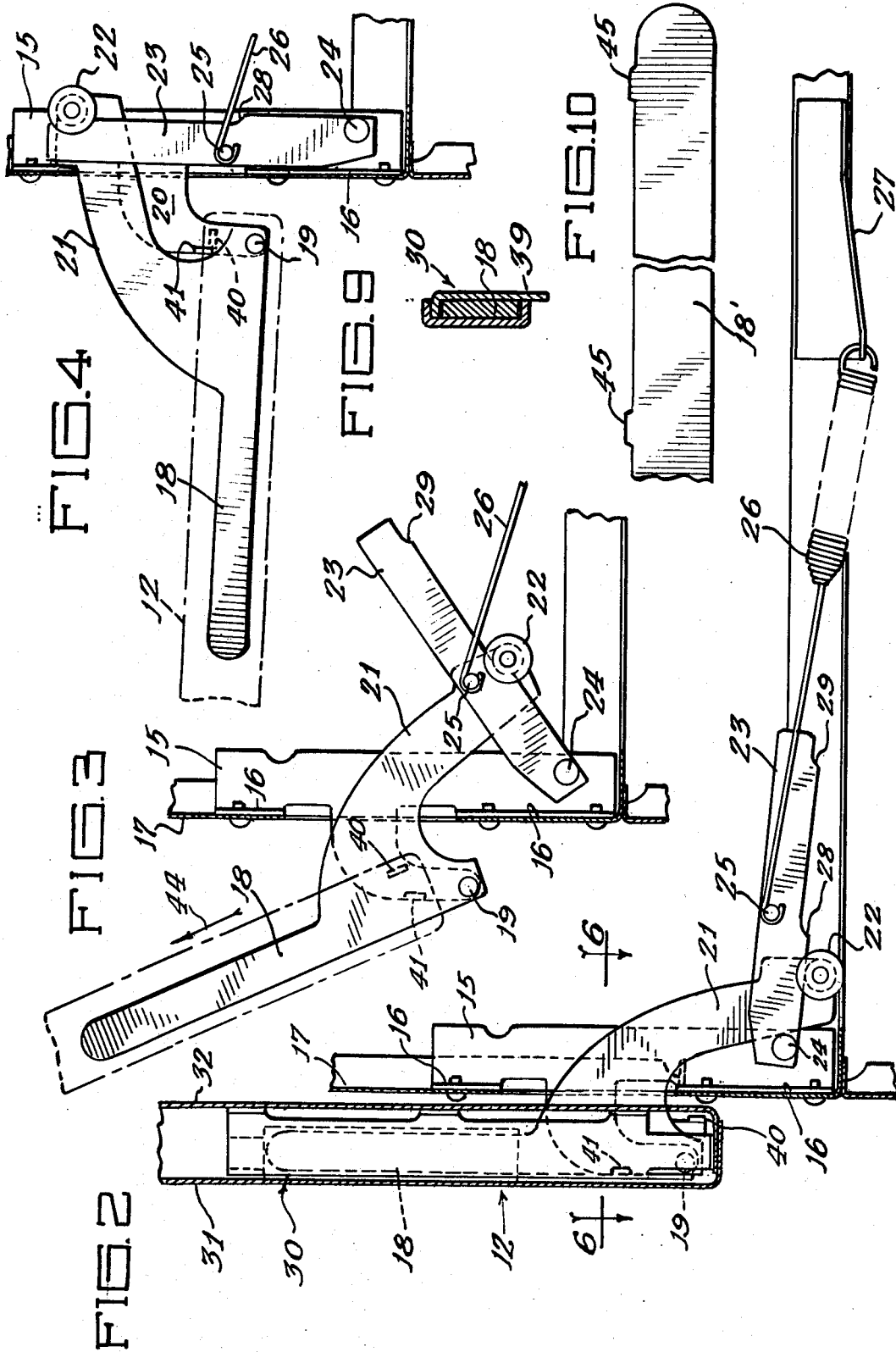

1

2

3,495,582

REMOVABLE DOOR CONSTRUCTION FOR OVENS

Michael W. Maier, Beaver Dam, Wis., assignor to
Malleable Iron Range Company, Beaver Dam,
Wis., a corporation of Wisconsin

Filed May 17, 1968, Ser. No. 730,133

Int. Cl. F24c 15/02

U.S. Cl. 126—191

6 Claims

ABSTRACT OF THE DISCLOSURE

The hinge means for the door comprises a hinge plate secured to the oven body, a stake, and a pivot connecting the stake to the hinge plate. The hinge plate is located so that the pivot is forwardly of the oven body and received within the confines of the oven door. The oven door includes a box which fits over the stake and can be removed by a freely sliding movement. The stake has an arcuate portion which extends rearwardly into the oven body and carries at its rear end a roller which bears on a cam lever movable between a rearwardly extending position and an upwardly extending position. A spring biases the cam lever into the rearwardly extending position. The cam lever has two detents providing two stabilized door positions, one being a partially open door position and the other being a fully open door position. A lug on the hinge plate interferes with a lug on the box when the door is in its fully open position to prevent removal of the door from the hinge, but the lugs do not interfere with each other when the door is in its partially open position.

This application relates to an improved removable door construction for oven ranges or the like.

It has heretofore been proposed to provide a removable oven door to facilitate cleaning of the oven. In the customary oven door construction the two hinge members are in the form of a hinge plate, secured to the oven body, and a stake, associated with the oven door, the hinge plate being so placed that the pivot point is disposed forwardly of the oven body and located within the confines of the oven door which is of substantial thickness. The stake includes an arcuate portion which extends into the wall of the oven body and is connected to a door closing spring.

The stake is telescopically received within a box carried by the door to permit removal of the door.

In order to prevent removal of the door when in its fully opened position, interlocking lugs are provided on the telescopic members, that is the stake and the box. It is very difficult to disengage the interlocking lugs when the door is in fully opened position for the reason that the door closing spring urges the lugs into interlocked position.

It has previously been proposed to provide a detent mechanism, in connection with the door closing spring, for maintaining the oven door in a partially opened or broil position. The prior art arrangements utilize this detent arrangement to "neutralize" the spring so that the door and the box may be manipulated, when in partially opened position, with respect to the stake which is now free from any spring bias.

However, it has been found that the average housewife encounters considerable difficulty in mastering this manipulative technique. Manipulation of the door involves the possibility that the stake will be dislodged from the critical position by the manipulations, in which event either the interlocking lugs cannot be disengaged, or if they have already become disengaged, the subsequent removal of the door will cause the stakes to snap back

to the fully closed position. When the door has been removed, the stakes cannot be retracted to the detent position without some tool to provide leverage.

As a result, it has been found that even though ovens are equipped with the removable door feature, some housewives, after one or two unsuccessful attempts to use the same, make little further use of it.

A further difficulty with this prior art arrangement is that it is necessary to rely solely on the door weight to maintain the door in its fully opened position. If a detent were provided, then the door could be removed in this position also, which is the situation that the use of the interlocking telescopic members is intended to avoid.

According to my invention I provide interlocking means between the door and the oven body which is operative only when the door is in its fully opened position. This accomplishes the objective of preventing door removal when it is fully opened. It also permits me to provide a second detent position which is operative when the door is in its fully opened position, thus providing a more positive door action.

This arrangement also permits me to eliminate the interlocking lugs which are the cause of difficulties outlined above. Therefore, the door is very easily removed when in the partially opened position merely by pulling it upwardly off of the stakes, and without resorting to any manipulation.

Furthermore, I have found that as a practical matter there is no tendency for the door to separate itself from the stakes in any position other than the detent stabilized position, unless it is intentionally yanked, because removal is resisted by the friction between the spring biased stake and the box.

Therefore, I have provided an exceedingly simple and effective construction which permits the door to be removed without manipulation when in the partially opened position, but which positively locks the door against removal when in the fully open position, and additionally, I am enabled to provide a detent for the fully open position.

Other objects, features and advantages will become apparent as the description proceeds.

In the drawings:

FIG. 1 is a front elevation of an oven range, with portions broken away to show portions of the hinge mechanism;

FIG. 2 is a side elevation of the hinge mechanism taken along line 2—2 of FIG. 1;

FIGS. 3 and 4 are side elevations of the hinge mechanism with the oven door in broken lines, and showing a changed position of the parts from the position shown in FIG. 2;

FIG. 5 is a front elevation of the box located within the confines of the oven door, a portion of the oven door being shown in section;

FIG. 6 is a horizontal section taken along line 6—6 of FIG. 2;

FIG. 7 is a perspective view of the box;

FIG. 8 is a perspective view of the hinge plate and stake;

FIG. 9 is a horizontal section taken along line 9—9 of FIG. 5; and

FIG. 10 is a side elevation of a modified stake.

In FIG. 1, the range 10 has an oven cavity 11 and an oven door 12, partially broken away. The side wall of the oven is hollow, providing a space 14 in which a portion of the hinge mechanism is located. The hinge mechanism is duplicated on the left side of the oven, and is not shown, since it is the same as the right hand hinge mechanism which is shown, except for right to left reversal.

As shown in FIG. 8, the hinge mechanism includes a

hinge plate 15 and a stake 18 which are connected to each other by a pivot 19. The hinge plate 15 includes tabs 16 by means of which it can be welded or screwed to the inner surface of the front panel 17 of the range body. The hinge plate includes a forwardly and downwardly projecting arm 20 which locates the pivot 19 at a point forwardly of the oven body, and within the confines of the oven door 12, as shown in FIG. 2.

The stake 18 includes an arcuate portion 21 which extends rearwardly through a slot, not shown, in the front body panel 17 and into the space 14. The inner and lower end of the arcuate portion 21 carries a roller 22 which rides on the under surface of a cam lever 23. The cam lever 23 is pivotally mounted on the hinge plate 15 by a pivot pin 24. A stud 25 on the cam lever provides a mounting for one end of an operating spring 26, the rear end being connected to an anchor flange 27 forming a part of the range structure.

In operation as the oven door 12, which is removably mounted on the stake 18, is swung from the fully closed position of FIG. 2 into an open position, the cam lever 23 is swung upwardly as shown in FIGS. 3 and 4, against the tension of the operating spring 26. This arrangement regulates the force exerted by the spring in accordance with the angular position of the oven door, as pointed out in my Patent No. 2,731,011 granted Jan. 17, 1956.

The cam lever 23 is provided with a detent 28 corresponding to the partially opened or broil position of the oven door, shown in FIG. 3, and with a second detent 29, corresponding to the fully open door position shown in FIG. 4.

The removable connection between the oven door and the hinge mechanism comprises two telescopic members, the stake 18, and the box 30, which receives the stake. The box 30 forms a part of the oven door and is located within same between the front and rear door panels 31 and 32, as shown in FIG. 2. The box is provided with tabs 33 by means of which it may be welded to the rear panel 32. The panels 31 and 32 are provided with bent overlapping margins which form the top, bottom and side edges of the oven door, according to the usual practice. An opening 34 is made in the overlapping margins, through which the stake extends as the oven door is being removed or replaced. A similar opening 43, is provided in the rear panel 32 to accommodate the arcuate portion 21 of the stake, as well as the arm 20 of the hinge plate 15, as shown in FIG. 6.

The box 30, as shown in FIGS. 5 and 7, comprises a narrow upper portion 35 in which the inner dimensions correspond with the cross section of the stake 18 so that the stake is received within the narrow portion 35 (FIG. 9) with a loose sliding fit, but no appreciable play. The lower part 36 of the box 30 is of greater width, and a sloping wall 37 connects the narrow and wider portions and serves as a guide plate to guide the stake 18 into the narrow part 35 as the oven door is being replaced. The upper part 35 can conveniently be made in two pieces 38 and 39, as shown in FIGS. 7 and 9, so that close control can be obtained of the inner dimensions of the narrow part 35.

The box is provided at its lower part with an inwardly extending lug 40, as shown in FIGS. 5 and 7. A lug 41 is provided on the arm 20 of hinge plate 15, as shown in FIG. 8. The lugs 40 and 41 are so positioned, being substantially equidistant from the pivot 19, that when the door is in its fully opened position as shown in FIG. 4, the two lugs interfere with each other to prevent removal of the door, the lug 40 swinging upwardly behind the lug 41 and being blocked thereby. A comparison of FIGS. 3 and 4 indicates that when the door is in its partially opened position, as shown in FIG. 3, the door may be pulled upwardly off of the stake, because there is no interference; the lug 40 is not blocked by lug 41.

By the use of the lugs 40 and 41 it is possible to pro-

vide the second detent 29 for the fully opened door position. Without the lugs, the detent 29 could not be used because it neutralizes the spring in the same manner as the detent 28, and thus permits removal of the door when the spring is fully tensioned. The detent 29 also permits the use of a construction in which the door moment is completely counterbalanced by the spring action, as contrasted with an arrangement in which the door must overbalance the spring if the detent is not used.

In operation, the door is first moved to the FIG. 8 position, which is a stable position due to the detent 28, and then the door is removed by an upward movement in the direction of the arrow 44. It is not necessary to manipulate the door with respect to the stake because there is no interlocking between the stake and the box. After the box is removed, the stakes will remain in the partially extended position while the oven is being cleaned. If the stake should become dislodged, the pivot pin 24 for the cam lever serves as a stop for the arcuate portion 21 of the stake, and thus prevents the stake from moving rearwardly into engagement with the front panel 17 of the oven body. The distance between the upper end of the stake 18 and the front panel 17, as shown in FIG. 2, is sufficient to accommodate a finger, so that if the stake does snap back, its motion will be arrested at the position shown and thus prevent serious injury to a finger which would otherwise be pinched.

On replacing the oven door, it is merely lowered over the stake 18 until the stake seats itself against the upper edge of the box 30, after which the oven door may be opened or closed in the usual manner.

It is easier to control the fit of the stake 18 within the upper part 35 of the box 30 if the stake 18' is provided with lands 45 as shown in FIG. 10, thus maintaining relative freedom of removal while avoiding any appreciable play.

Although only a preferred embodiment of my invention is shown herein, it will be understood that various modifications and changes may be made in the construction shown without departing from the scope of my invention, as pointed out by the appended claims.

I claim:

1. A removable door construction for an oven comprising an oven body defining an oven cavity, a door for said oven cavity, hinge means connecting said oven door and said body, said oven door and said hinge means having first and second telescopic members respectively for removably mounting said oven door on said hinge means and movable with said door, said hinge means also including a stationary hinge plate mounted on said oven body and a pivot connecting said hinge plate with said second telescopic member, a cam lever pivotally mounted on said oven body and movable between an upright position and rearwardly extending position, said second telescopic member including a rearwardly extending portion, means mounted on said rearwardly extending portion and engaging said cam lever, spring means biasing said cam lever into said rearwardly extending position, a detent on said cam lever cooperating with said lever engaging means to provide a partially open oven door position, and means for preventing removal of said oven door from said second telescopic member when said oven door is in its fully opened position, said means comprising a first lug on said first telescopic member and movable therewith, and a second lug on said stationary hinge plate, said lugs being located for interference with each other when said door is in its fully opened position, said first lug being movable by the movement of said door from a normally non-interfering position when said door is in said partially open position into an interfering position when said door is moved into its fully opened position.

2. A removable oven door construction as claimed in claim 1 in which said telescopic members are free from

5

interlocking portions so that said oven door can be withdrawn from said second telescopic member by a simple sliding movement when said door is in said partially open position.

3. A removable oven door construction as claimed in claim 1 in which said cam lever has a second detent providing a fully open door position, said spring means and said cam lever providing a door closing moment which is greater than the moment provided by the weight of said door when in fully open position.

4. A removable door construction for an oven comprising an oven body defining an oven cavity, a door for said oven cavity, hinge means for said door comprising a hinge plate secured to said oven body, a stake, and a pivot connecting said stake and said hinge plate, said oven door including an elongate box structure receiving said stake, a cam lever pivotally mounted on said oven body and movable between an upright position and a rearwardly extending position, said stake including a rearwardly extending portion, a roller mounted on said rearwardly extending portion and engaging said cam lever, spring means biasing said cam lever into said rearwardly extending position, a detent on said cam lever cooperating with said roller to provide a partially open oven door position, and means for preventing removal of said oven door from said stake when said oven door is in its fully opened position, said means comprising a first lug on said box structure located rearwardly of said pivot when said door is in its fully closed position, and a second lug on said hinge plate located above said pivot and forwardly of said first lug when said door is in its fully closed position, said lugs each being substantially equidistant from said pivot so as to interfere with each other when said door is in its fully opened position.

5. A removable door construction as claimed in claim 4 in which said rearwardly extending stake portion is an arcuate portion extending into said oven body, said hinge plate including a forwardly and downwardly extending portion, the lower end of which is located forwardly of

6

said oven body, said pivot being located at said lower end.

6. A removable door construction for an oven comprising an oven body defining an oven cavity, a door for said oven cavity, hinge means connecting said oven door and said body, said oven door and said hinge means having first and second telescopic members respectively for removably mounting said oven door on said hinge means and movable with said door, said hinge means also including a stationary hinge plate mounted on said oven body and a pivot connecting said hinge plate with said second telescopic member, spring means biasing said door into closed position, first detent means providing a first stabilized door position corresponding to a partially open door position, second detent means providing a second stabilized door position corresponding to fully open door position, said telescopic members having a freely sliding movement to permit removal of said door from said hinge means in said first door stabilized position, and interfering means for preventing removal of said oven door from said hinge means when said oven door is in its second stabilized position, said interfering means comprising a first lug associated with said door and movable therewith, and a stationary lug associated with said oven body, said first lug being movable by the movement of said door from a normally non-interfering position when said door is in said partially open position into an interfering position when said door is moved into its fully opened position.

References Cited

UNITED STATES PATENTS

| | | | |
|-----------|--------|--------------|---------|
| 2,731,011 | 1/1956 | Maier | 126—191 |
| 3,040,731 | 6/1962 | Mudd | 126—191 |
| 3,090,375 | 5/1963 | Nelson | 126—194 |
| 3,150,659 | 9/1964 | Ellis et al. | 126—194 |

KENNETH W. SPRAGUE, Primary Examiner

U.S. Cl. X.R.

126—194